



Central University of South Bihar

(A Central University established under Central Universities Act 2009)

(Notice Inviting Tender)

NIT No.: CUSB/PSD/LAW/Tender/03/2020-21

Dated: 01/09/2020

Sealed item rate tenders are invited from manufactures, Suppliers (or their 'authorized' dealers), Contractors for providing & fixing of the following items for its Permanent Campus site at Panchanpur, Gaya, Bihar- 824236.

Sr. No.	Tender No.	Description of the item	Estimated cost
1.	NIT No. CUSB/PSD/LAW/Tender/03/ 2020-21	Annexure '1' Attached	Rs. 8,00,000/- (Approx.) (Rupees Eight Lakhs Only)

The subject tender covers the major scope of furniture for **Establishing the Moot Court and Legal Aid Clinic**. The tender documents (non-transferable) along with detailed specifications and terms & conditions (available on) can be downloaded from the University website www.cusb.ac.in and must reach the office of **Registrar (TENDER DOCUMENT), CENTRAL UNIVERSITY OF SOUTH BIHAR, Administrative Building, Gaya Tekari Road, Panchanpur, Gaya - 824236 (Bihar) by registered post / speed post/ by hand.**

The last date for submission of duly filled tender documents is **21/09/2020**. Application/(s) received after last date of submission will not be considered.

Read carefully the tender documents and also note the following important dates.

S.N.	Important Dates related to Tender	Details
1	Tender Notice No.	CUSB/PSD/LAW/Tender/03/2020-21 Dated : 01/09/2020
2	Name of work	Supply & Installation of Furniture for "Establishing the Moot Court and Legal Aid Clinic" in LAW Dept., CUSB
3	Tender Fee	Rs. 500/- in shape of DD
4	Earnest Money Deposit	Earnest money of Rs. 30,000/- in shape of Demand Draft drawn in favour of Central University of South Bihar, payable at Gaya from any scheduled Bank.
5	Start Date of Tender	01/09/2020 by 11:00 AM
7	Pre-bid Meeting in the office of Tender Inviting Authority; Date and Time	08/09/2020 by 11:00 AM at CUSB Gaya
8	End Date and Time of Submission of Bid	21/09/2020 by 04:00 PM
9	Date & Time of Technical Bid Opening	22/09/2020 by 11:00 AM

(Registrar)

Sealed item rate tenders are invited under Two Bid System from Manufactures, Suppliers (or their 'authorized' dealers), Contractors for providing and fixing the items as mentioned in Annexure '1'.

1.1.1. Eligibility Criteria

1.1.2. Financial

1.1.2.1 The Firm should have Average annual financial turnover of at least 100 % of the estimated cost during the preceding last 3 consecutive financial years.

1.2.1. Physical

1.2.1.1. Three similar works in Central Government/ state Government/ PSU/ Universities/ Reputed Higher Educational Institutions costing not less than 40% of the estimated cost or two similar works costing not less than 60% of the estimated cost or one similar work costing not less than 80% of the estimated cost in the last 7 years ending on the last day of the month previous to the one in which the tenders are invited.

1.2.1.2. Similar Work is defined as Supply of Wooden Furniture in Central Government/ state Government/ PSU/ Reputed Govt Educational/ Higher Educational Institutions or having wood work as item in the composite Civil work of buildings executed with Central Government/ state Government/ PSU/ Reputed Government/Private Educational Institutions.

2.0. Bid Submission: The Tender Documents for items will be on **two-Bid System** consisting of **Technical Bid** and **Price Bid**. The process of evaluation of bids shall be done in two phases as under:

2.1. Technical Bid: Bidders shall be required to submit all documents related with the tender requirement in one Envelope labeling the same as "Technical Bid" as Envelope-A. Applications incomplete in any respect, viz. non-submission of any required document or information, or fee in requisite amount are liable for rejection.

2.1.1. Envelope- A

The sealed envelope containing the Technical BID documents & fee should be clearly super-scribed on the top of the envelope as "**TECHNICAL BID DOCUMENTS** "

2.1.2. The following self-certified essential documents (as applicable) should accompany the Technical Bid Proforma:

1. Check List
2. GST Certificate
3. Income Tax - Permanent Account No. (PAN)
4. Copy of Small Scale Unit/ MSME/ NSIC Registration under relevant items.
(If Registered)
5. Annual Turnover CA certified Certificate for last 3 years & Copy of IT Return for the year (2018-19, 2017-18, 2016-17).
6. Copy of certificate of meeting minimum eligibility criteria (as per Clause No 1.1.2 & 1.2.1)
7. Bank Details.

8. Trade License, Factory License/Excise Registration.
9. Current dealership Agreement /Registration Certificate from the Principal.
10. Memorandum and Article of Association, Certificate of Incorporation, Partnership Deed, Registration Certificate issued by the Registrar of Firms etc.
11. All pages of Tender document except Bill of Quantities.
12. Un-priced copy of Bill of Quantity with "Nil" written in Rate and amount Column.
13. Earnest Money Deposit in form of Bank Draft for an amount of **Rs 30,000/-** (Rupees thirty thousand only) drawn in the Central University of South Bihar payable at Gaya.
14. Price of Tender Document [Non Refundable] in form of Bank Draft for an amount of **Rs 500/-** (Rupees Five Hundred Only) drawn in the favour of Central University of South Bihar, payable at Gaya.
15. A notarized certificate that the Organization hasn't been black listed by any institution of the Central/ State government / any PSU, University, Institute etc. in the past three years.

2.1.3. Envelope- B: This Contains Price Bid Only: Duly Sealed and signed Bill of Quantity pages to be put in to envelope labeled as "Price Bid" Envelope 'B'.

2.1.4. The duly sealed & signed Tender Documents as stated above to be put in one big envelope and same has to be labeled with "Techno-commercial Bid", Tender Number, Due date of Submission, Name & address of the bidder and has to be submitted with in due time of closure of Technical Bid submission either by **Registered post/ Speed Post/by hand** to the "**Registrar (TENDER DOCUMENT), Central University of South Bihar, Administrative Building, Gaya Tekari Road, Panchanpur, Gaya - 824236 (Bihar)** on or before the due date and time i.e. **21/09/2020 by 4.00 PM**

2.1.5. Bid Evaluation Criteria: Shall be done after checking of authenticity of documents produced along with Techno-commercial Bid.

Note: *In no case, bidders shall quote prices in any of the document during and with Technical Bid submission. Price bid to be submitted only in separate envelope.*

2.1.6. Site Visit: Bidders are requested to visit the site of Central University of South Bihar, Village- Panchanpur, Gaya, Bihar- 824236. Supply and Installation of items under the subject tender has to be carried out at the above location. Bidders should get themselves satisfied with the site conditions, environment, transportation and other socioeconomic factors etc. before quote. Any afterthought expressions after award of the job shall not be entertained.

2.1.7. Tender Documents: The tender documents (non-transferable) along with detailed specifications and terms & conditions can be obtained from CUSB website www.cusb.ac.in.

2.1.8. Forms can be downloaded and used along with payment of non-refundable tender price as mentioned below. The Tender price may be paid in the form of Bank Draft for an amount of **Rs. 500/-** (Rupees Five Hundred Only) in favour of Central University of South Bihar payable at Gaya separately along with the demand draft of Earnest Money Deposit of **Rs. 30,000/-** (Rupees Thirty Thousand Only).

2.2. No Tender/ documents shall be accepted after due date and time of bid submission.

2.3. Language of Bid shall be English Only.

- 2.4. Canvassing in any form shall be liable to rejection of Bid without assigning any reason by Tender Inviting Authority.
- 2.4.1. The University shall not be responsible for any delay in receiving Bids for what so ever reasons.
- 2.4.2. The University reserves the right to accept or reject any bid, without assigning any reason thereof. No correspondence in this regard will be entertained.
- 2.4.3. This document is treated as a valid contract between CENTRAL UNIVERSITY OF SOUTH BIHAR and Vendor and adherence to all aspects of fair trade practices in executing the work orders placed by the University.
- 2.4.4. In case the vendor is found in breach of any terms & condition(s) of the University or work order, at any stage during the course of supply / installation or warranty period, the legal action as per rules/laws, shall be initiated against the vendor and EMD/Security Deposits shall be forfeited by the University besides debarring and blacklisting the vendor concerned for at least three years for further dealings with the CENTRAL UNIVERSITY OF SOUTH BIHAR.
- 2.4.5. The vendor should not assign or sublet the work or any part of it to any other vendor in any form. Failure to do so shall result in termination of contract.
- 2.4.6. The vendor to whom work order has been issued is expected to maintain absolute integrity, follow a decent standard of business ethics.
- 2.5. **Priced Bid**
- 2.5.1. **Pre-Bid meeting:** A Pre-bid meeting shall be conducted for clarification of queries raised by bidders, if any on technical or commercial requirements related with subject bid. Bidders are requested to email their queries with reference of clauses to following email Ids: registrar@cub.ac.in; ee@cusb.ac.in. The last date of receipt of queries shall be 08/09/2020 till 11.00 AM. **Pre-bid meeting shall be held on 08/09/2020 at 11.00 AM** onwards at Central University of South Bihar, Gaya.
- 2.5.2. Any Corrigendum/ information shall be published and displayed on website only.
- 2.5.3. Bidders should understand the requirement of material/ services as per samples approved and displayed, Design, drawings, Technical specification & Bill of Quantity. Accordingly, rate to be quoted. Scope of supply of vendor and Scope of supply of Owner to be understood thoroughly by the bidders while quoting their rates.
- 2.5.4. Bidder should quote their rates, amount and other details in the prescribed format of "Bill of Quantity". While filling the said Bill of Quantity, rate and amount to be written in numeric as well as in word. Bidders should fill the priced bid format very carefully to avoid any corrections, overwriting etc. Any overwriting and/ or correction on price bid shall be summarily rejected. After quoting the rate in format of "Bill of Quantity", bidders shall seal the same in an Envelope and same has to be labeled with "Priced Bid" Envelope 'B', Tender Number, Name and address of the Bidder.
- 2.5.5. Bidders to send their representatives by authorizing them in writing to be present during Pre-bid meeting, opening of Technical bid as well as in Priced Bid.

2.5.6. Work shall be awarded to the vendor who will be over all lowest in price after evaluation of quoted rates in all items.

2.6. Tender Inviting Authority reserves the right to award the job to lowest bidder and or may summarily cancel the Tender.

3.0. Scope of Vendor

3.1. Submission of Performance Guarantee in form of Demand Draft or Bank Guarantee for an amount equivalent to 10% of the awarded value. The Performance Guarantee to be submitted within One month of date of award of the contract. Date of award of the contract shall be reckoned from the date of issue of Letter of Acceptance (LOA).

3.2. Vendor has to execute an agreement within 15 days of the issuance of LOA and must before submission of Bill whichever is earlier.

3.3. Vendors are required to submit Shop drawing for item of the Bill of quantity within 10 days from the date of issue of LOA. Owner/ Engineer In-charge shall check the drawing and ask the vendor to incorporate comments, if any. Vendor shall resubmit the shop drawing after incorporation of all comments so as to satisfy the instruction of Owner/ Engineer-In charge within 7 days of receipt of the comments. Minor variation in specification, drawings related to items may take place and vendor shall be required to execute the same without any additional implication of cost and time.

3.4. Vendor shall construct its own store and fabrication yard fully secured to store and for fabrication of material at site. Owner shall provide open land only adjacent to buildings for construction of temporary store/ fabrication yard. Vendor shall remove the same and make the area good and cleaned from all debris after completion of job at their own. Cost towards construction of such temporary facility and dismantling after completion of work will not be borne by the University. Nothing extra shall be paid on account of above.

3.5. Vendor has to arrange their own security, watch & ward of their assets and materials brought at site for the work. Owner/ Engineer In-charge shall not be responsible for any kind of pilferage, loss, damage & breakage etc on account of any incidence/ act.

3.6. Vendor has to obtain Contractor's All Risk (CAR) Policy for the value of contract till completion of work from competent agency and submit the Notorised copy of the same to Owner/ Engineer In-charge within 15 days of issuance of LOA.

3.7. Vendor has to obtain labor license for fabrication and installation work at site. In addition to above, vendor has to obtain Workmen Compensation Policy from the designated agency for the category and quantum of labors required till completion of the job.

3.8. All labors deployed in work should be covered with Provident Fund scheme and E.S.I as per the directives of Statutory Authority. A copy of submitted challan shall be required with bills submitted by vendor to Owner/ Engineer—In charge for receipt of payment.

3.9. Inspection

(a) Inspection at the source of production of material shall be carried out by the Owner/ Engineer In-charge before dispatch of material. Vendor has to offer such call at least 7 days in advance in writing. However, inspection does not relive vendor from ensuring confirmation of material with agreed specifications, quality, size, texture and finishes etc.

(b) All fabricated materials at site to be inspected by Owner/ Engineer-In-charge before application of paint/ primer and polish. Any material polished/ painted before such inspection shall be rejected and no payment shall be released towards the same.

3.10. Vendor should carry out the job at site in such a manner to avoid any damage to existing facility/ ongoing work in the buildings. Bidders should take utmost care while shifting the assemblies/ members/ fabricated furniture to avoid any rubbing with adjacent walls and floor. Any damage caused to the existing facility, ongoing work must be rectified and made good by the vendor. In event of failure in such rectification/ replacement, the job shall be done by Owner through other agency at the risk and cost of the vendor.

3.11. While installation of furniture in room/ hall, a layout on floor to be provided with location of Anchor/ fasteners by erasable ink to cross check the space plan before installation. A copy of such lay out plan to be kept for record and submitted with (Running Account) RA Bills and As-built drawings in soft as well as hard copy along with final bill.

3.12. Wherever applicable, size and type of Anchor fasteners to be suggested and provided by vendor with their experience and previous installation, so as to ensure no damage to finished flooring which shall be Vitrified tiles of 9/10 mm thick on 20 mm average cement mortar or Granite flooring of 18 mm+/- 1 mm with 20 mm average thickness of cement mortar. Further, vendor shall use Heavy duty zinc plated concrete anchors to withstand a rigid assembly cast iron (C.I.) frame with floor & wall without any gap and vibration after installation. Vendor shall submit Sample of Anchor fastener for obtaining approval of owner/ engineer In-charge.

3.13. All materials brought in site should be fully seasoned and meet technical specifications. All materials should accompany with valid invoices, Excise challans, forest clearance certificates and Manufacture's Test Certificate, if applicable with each lot of materials. Vendor shall submit copy of all documents as stated above with bills. Vendor shall be held responsible for any kind of mischief/ manipulation of documents, if found and action shall be taken against vendor as per law. The University will not be liable in any circumstances due to failure of any legal compliance on the part of vendor.

3.14. Vendor should separately stock the wastages, cut-pieces and other salvage material and shall obtain written permission of Owner/ Engineer In-charge prior to removal/ disposal of the same.

3.15. Vendor and their representative shall strictly ensure Safety while working in site and Personal Protective Equipment to be used while carrying out the work.

3.16. Adequate number of sample of wood material with lot shall be sealed and signed jointly and shall be sent to Third Party Testing Laboratory (Preferably Government Laboratory) for Physical and Chemical test, if required as per relevant Bureau of Indian Standard (BIS) and code of practices. All material shall only be accepted for acceptance, once test report confirms its authenticity as per specification. All charges towards cost of samples, transportation, sampling and testing to be borne by contractor and cost towards same is deemed to be included in the rate quoted by the vendor.

A. Indemnity

The vendor to whom work order has been issued shall indemnify the CENTRAL UNIVERSITY OF SOUTH BIHAR and user departments against all third party claims of infringement of patent, trademark/copyright or industrial design rights arising from the use of the supplied items and related services or any part thereof.

User department stand indemnified from any claims that the vendor's manpower may opt to have towards the discharge of their duties in the fulfilment of the purchase orders.

B. Termination for Default

a) Default is said to have occurred i) if the vendor fails to deliver any or all of the services within the time period(s) specified in the work order or any extension thereof granted by the University. ii) If the vendor fails to perform any other obligation(s) as mentioned in the tender documents.

b) If the vendor, in either of the above circumstances, does not take remedial steps within a period of 15 days after receipt of the default notice from the University (or takes longer period in spite of what the University may authorize in writing), The University may terminate the work order in whole or in part.

All disputes in this connection shall be settled in Gaya Jurisdiction only.

3.17. Unless and otherwise specified all cost towards material, transportation, all taxes, duties, wastages, labor, insurances, transit insurance, storage, shifting, lead and lift, carriage, staffs, accommodation, welfare measures for staffs and labors, labor wages & benefits and other incidental expenses etc. are deemed to be included in the rate quoted by the vendor. Nothing extra shall be paid on account of above.

3.18. Mode of Measurement: Unit of measurement shall be "Each" and shall be certified on counting the goods.

3.19. Rates are invited for furniture made out of Two kind of Solid hard wood namely, Red Sheesham & 2nd Class Teak wood.

4.0. Payment Terms

Payment shall be made in stages:

1st Stage: 70% of the item rate shall be paid after receipt of raw material at site and joint inspection by Engineer-In charge subjected to submission of mandatory purchase invoices, Quality reports (mandatory).

2nd Stage: 30% of the item rate shall be paid after successful fabrication and final polishing/ painting/ installation of the items subject to satisfactory report by the Engineer-In-Charge.

5.0. S.D. Clause : 10% of the contract value shall be submitted by the vendor as Security Deposit in form of DD/BG/Bank Deposit in favour of Registrar, Central University of South Bihar payable at Gaya by any scheduled bank.

6.0. Completion Time: Completion Time for Entire Scope of Work shall be 03 months from the date of issuance of Letter of Award.

7.0. Defect Liability Period: Defect Liability period of the subject job shall be 1 year from the completion of job in all respect subject to issuance of virtual completion certificate by Engineer In-charge. Any defects found during above period shall be brought to the notice of the vendor and same has to be rectified within 7 days. If the vendor fails to rectify the defect during above period, same shall be made good/ rectified by other agency at the risk and cost of the vendor.

8.0. All disputes in this connection shall be settled in Patna/Gaya Jurisdiction only.

Detailed Technical Specification for establishing of Moot Court and Legal Aid Clinic

To be read in conjunction with Bill of Quantity, Drawings and Scope of Vendor.

S.No.	Item	Qty
1	Wooden Platform with both side steps : Providing and fixing Wooden Platform of size 6800x2400x300mm with 02 nos. steps of size 1800x300x150mm made up of Pine wood & Plywood. The platform structure shall be made of 110x35mm & 282x35mm pine wood panels of required length as per detailed drawing. The steps shall be made of 132x35mm & 70x35mm pine wood panels of required length as per detailed drawing. The top surface of the platform & steps shall be covered with 18mm thick MR plywood. The cost is inclusive of all labour and material etc. complete in all respect as per detailed drawing and direction given by engineer in charge. Please refer drawing for more details.	1
2	Wooden Judge Table : Providing and placing wooden Judge Table of size 4000x900x900mm made up of made up of seasoned and chemically treated Red Sheesham Wood and Sheesham Veneered Plywood with melamine polish of approved shade. The table structure shall be made of 110x28mm/100x28mm/70x28mm/38x38mm thick sheesham wood in required length and front/side panels shall be made of 12mm thick sheesham veneered plywood as per detailed drawing. The top shall be made of 18mm thick sheesham veneered plywood. The cost is inclusive of all labour and material etc. complete in all respect as per detailed drawing and direction given by engineer in charge. Please refer drawing for more details.	1
3	Wooden Court Master Table : Providing and placing wooden Court Master Table of size 1350x750x900mm made up of made up of seasoned and chemically treated Red Sheesham Wood and Sheesham Veneered Plywood with melamine polish of approved shade. The table structure shall be made of 110x28mm/100x28mm/70x28mm/38x38mm thick sheesham wood in required length and front/side panels shall be made of 12mm thick sheesham veneered plywood as per detailed drawing. The top shall be made of 18mm thick sheesham veneered plywood. The cost is inclusive of all labour and material etc. complete in all respect as per detailed drawing and direction given by engineer in charge. Please refer drawing for more details.	2
4	Wooden Executive Table : Providing and placing wooden Executive Table of size 1500x1200x900mm made up of made up of seasoned and chemically treated Red Sheesham Wood and Sheesham Veneered Plywood with melamine polish of approved shade. The table structure shall be made of 110x28mm/100x28mm/70x28mm/38x38mm thick sheesham wood in required length and front/side panels shall be made of 12mm thick sheesham veneered plywood as per detailed drawing. The top shall be made of 18mm thick sheesham veneered plywood. The cost is inclusive of all labour and material etc. complete in all respect as per detailed drawing	1

	and direction given by engineer in charge. Please refer drawing for more details.	
5	<p>Wooden Chair : Providing & placing of wooden Chair of size 500x490x1000H mm made up of seasoned second class teak wood with Melamine polish of approved shade. Front legs 50x50mm tapered to 40x40mm/ Back legs 40x40mm square. Back rest horizontal panel 02nos. 65x28mm & vertical panel 04 nos. 40x20mm. Front/side/back panels below seat of size 65mmx28mm total 4 nos.. Connecting panels as support between front and back legs will be of size 30mmx28mm to be provided on sides & back only. Seat foam to be 70mm thick 40 density PU foam of reputed brand pasted on 12mm thick MR plywood. Total seat thickness will be 82 mm covered with good quality fabric/leatherette in approved colour and texture. Total sitting height from floor till seat to be 470mm. Plastic buffers to be provided under legs. The cost is inclusive of all labour and material etc. complete in all respect as per drawing and direction given by Engineer in charge. Please refer drawings for more details.</p>	3
6	<p>Wooden Witness Box : Providing and placing wooden Witness Master Box of size 820x750x1180mm made up of made up of seasoned and chemically treated Red Sheesham Wood and Sheesham Veneered Plywood with melamine polish of approved shade. The structure shall be made of 85x28mm/100x28mm/38x38mm thick sheesham wood in required length and front/side panels shall be made of 12mm thick sheesham veneered plywood as per detailed drawing. Platform 150mm high made of 18mm thick MR plywood to be provided. The cost is inclusive of all labour and material etc. complete in all respect as per detailed drawing and direction given by engineer in charge. Please refer drawing for more details.</p>	2
7	<p>Wooden Podium : Providing and placing wooden Podium of size 600x450x1200mm made up of made up of seasoned and chemically treated Red Sheesham Wood and Sheesham Veneered Plywood with melamine polish of approved shade. The structure shall be made of 65x28mm/100x28mm/38x38mm thick sheesham wood in required length and front/side panels shall be made of 12mm thick sheesham veneered plywood as per detailed drawing. The top shall be made of 18mm thick sheesham veneered plywood and shelf made of 18mm thick MR Plywood. The cost is inclusive of all labour and material etc. complete in all respect as per detailed drawing and direction given by engineer in charge. Please refer drawing for more details.</p>	8
8	<p>Sofa 03 Seater : Supplying and Fixing 3 seater sofa of size be 1900 Lengthx700 Widthx880 Height. Seating Area Length– 1650mm. Clear Seating Area Width– 500mm. Seat Height from Ground– 450mm. Armrest height 630mm, Backrest height 880mm from floor. STITCHING shall be done by Nylon thread. . INNER frame work material shall be hardwood Babool having moisture content less than 14%. Thickness of Plywood used (mm) shall be 12mm. Standard of Plywood used shall be Standard : IS 303 Commercial Plywood. SEAT FOAM Thickness (mm) shall be 125mm which is a mixture as 25mm 32 Density Supersoft + 100mm 32</p>	2

	<p>Density. It shall be Slabstock foam. ARMREST FOAM & Backrest foam shall be 50mm thick 32 density foam . The sofa backrest shall have 75mm thick foam which is a mixture as 25mm 32 Density Supersoft + 50mm 32 Density. Exposed wooden base/legs of sofa shall be hardwood Red Sheesham .The sofa base shall have 4 legs of 50x50x150mm and 4 wooden frames 60x18mm thick connecting all 4 legs finished with melamine polish of approved shade. Fixing of base shall be done by Self Tapping screws. The sofa seat shall have 9 nos. of S- Springs running across front to back and 04 nos. of elastic band (niwar) running across the length. Sofa to be covered with good quality fabric/leatherette of approved shade. The cost is inclusive of all labour and material etc. complete in all respect as per detailed drawing and direction given by engineer in charge. Please refer drawing for more details.</p>	
9	<p>Sofa 01 Seater : Supplying and Fixing 1 seater sofa of size be 850 Length x 700 Width x 880 Height. Seating Area Length– 600mm. Clear Seating Area Width– 500mm. Seat Height from Ground– 450mm. Armrest height 630mm, Backrest height 880mm from floor. STITCHING shall be done by Nylon thread. . INNER frame work material shall be hardwood Babool having moisture content less than 14%. Thickness of Plywood used (mm) shall be 12mm. Standard of Plywood used shall be Standard : IS 303 Commercial Plywood. SEAT FOAM Thickness (mm) shall be 125mm which is a mixture as 25mm 32 Density Supersoft + 100mm 32 Density. It shall be Slabstock foam. ARMREST FOAM & Backrest foam shall be 50mm thick 32 density foam. The sofa backrest shall have 75mm thick foam which is a mixture as 25mm 32 Density Supersoft + 50mm 32 Density. Exposed wooden base/legs of sofa shall be hardwood Red Sheesham .The sofa base shall have 4 legs of 50x50x150mm and 4 wooden frames 60x18mm thick connecting all 4 legs finished with melamine polish of approved shade. Fixing of base shall be done by Self Tapping screws. The sofa seat shall have 9 nos. of S- Springs running across front to back and 04 nos. of elastic band (niwar) running across the length. Sofa to be covered with good quality fabric/leatherette of approved shade. The cost is inclusive of all labour and material etc. complete in all respect as per detailed drawing and direction given by engineer in charge. Please refer drawing for more details.</p>	4
10	<p>Wooden Centre Table : Providing and placing wooden Centre Table of size 1200x600x450mm made up of made up of seasoned and chemically treated Red Sheesham Wood with melamine polish of approved shade. Top 28m thick, 65x28mm front /side frames below the top, legs 75x75mm in required length as per detailed drawing. The cost is inclusive of all labour and material etc. complete in all respect as per detailed drawing and direction given by engineer in charge. Please refer drawing for more details.</p>	2
11	Providing Indian Emblem size 500x300x28 size 10 inch made of wood.	1
12	Providing Wooden Hammer size 10 inch (with Base) made of wood.	1

Platform With Both Side Steps
Platform Size : 6800x2400x300
Step Size : 1800x300x150

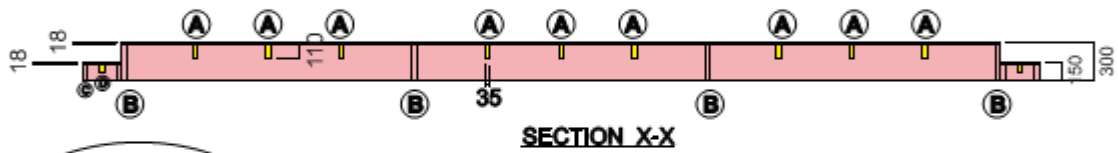
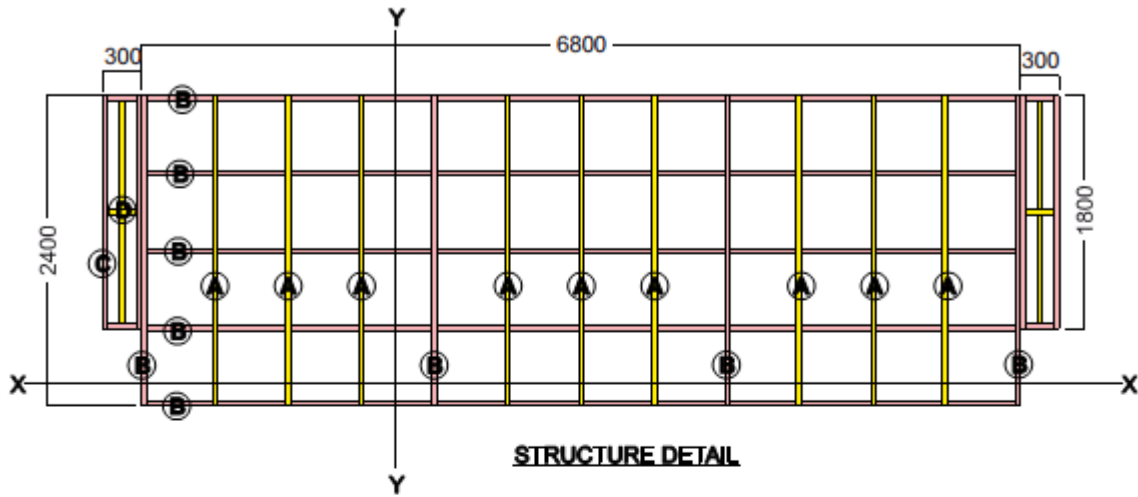

- A** = 110x35mm Panels
- B** = 282x35mm Panels
- C** = 132x35mm Panels
- D** = 70x35mm Panels

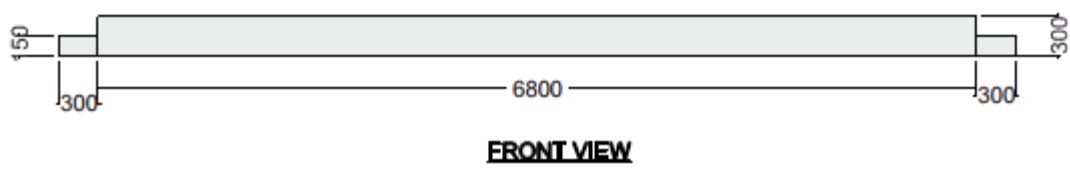
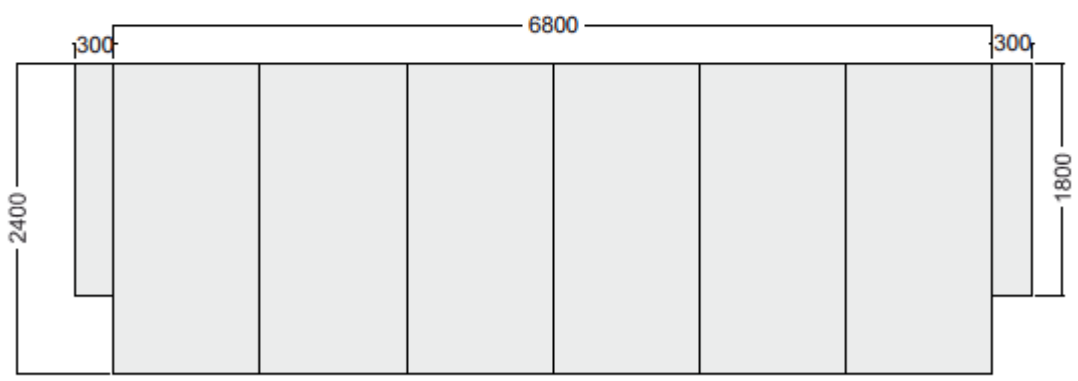
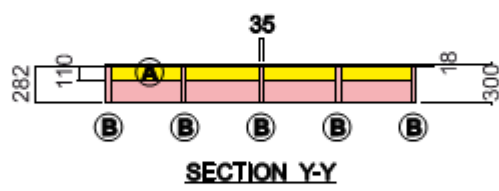

Judge Table
Size : 4000x900x900

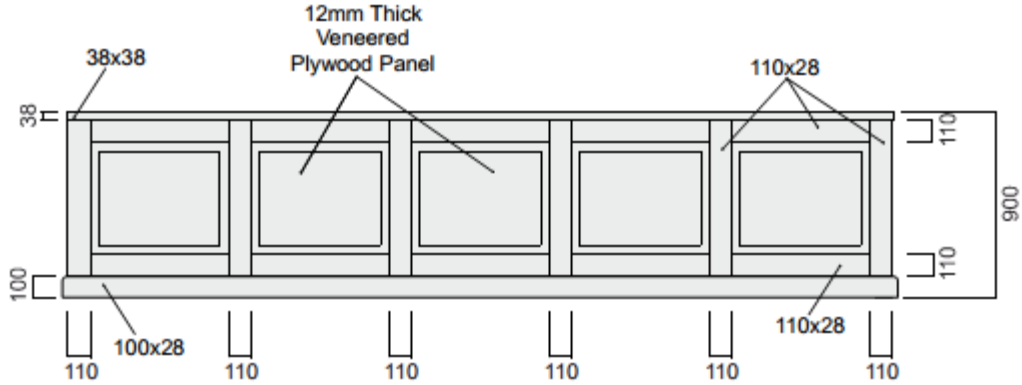

FRONT VIEW

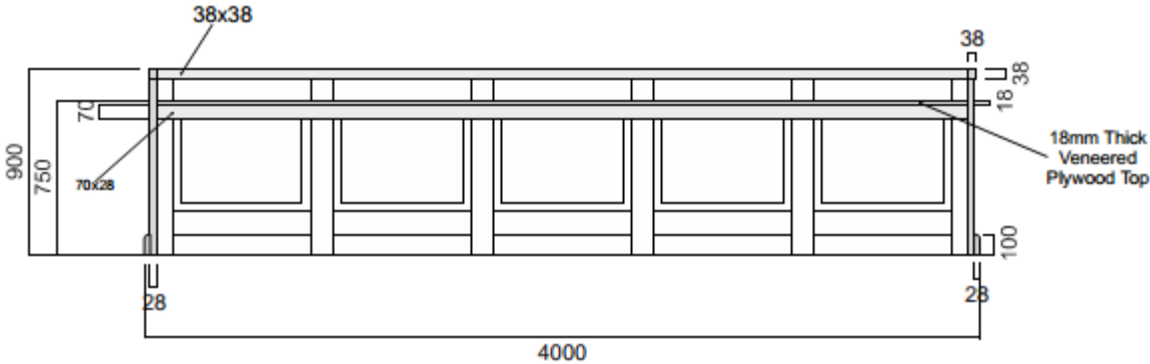

BACK VIEW

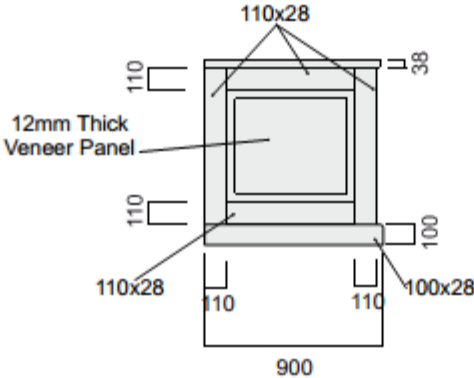

SIDE VIEW

Court Master Table
Size : 1350x750x900

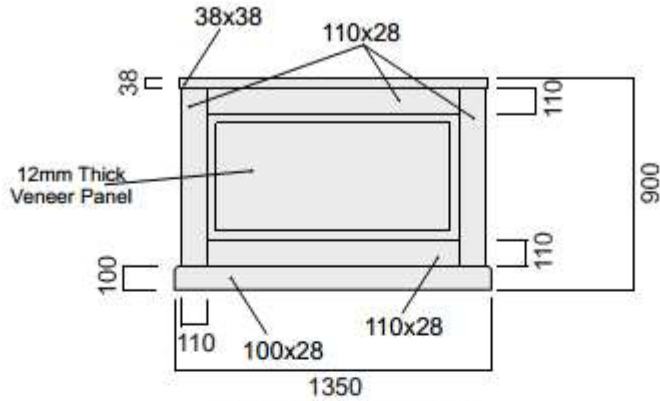

FRONT VIEW

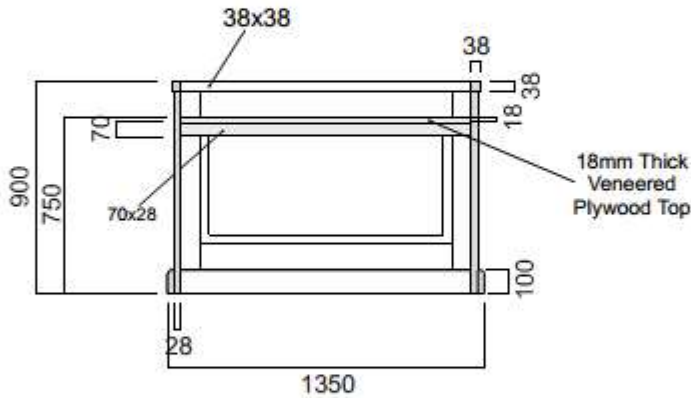

BACK VIEW

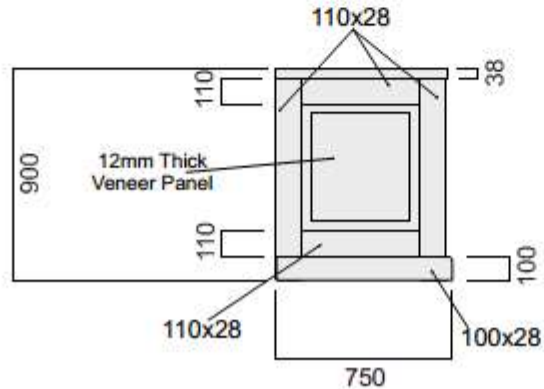

SIDE VIEW

Executive Table
Size : 1500x1200x900

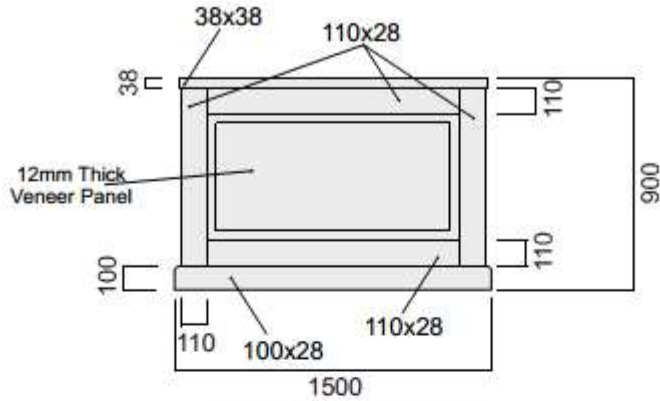

FRONT VIEW

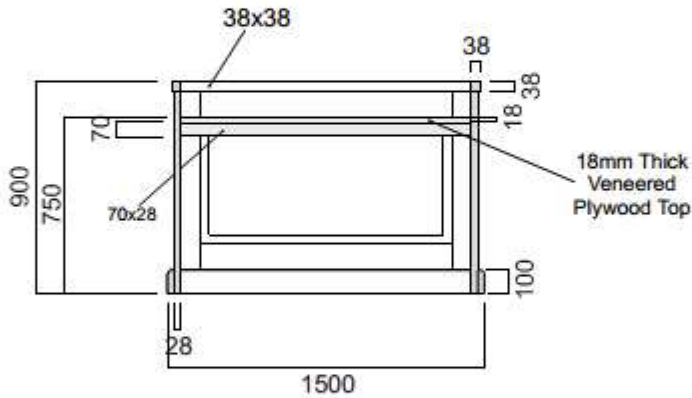

BACK VIEW

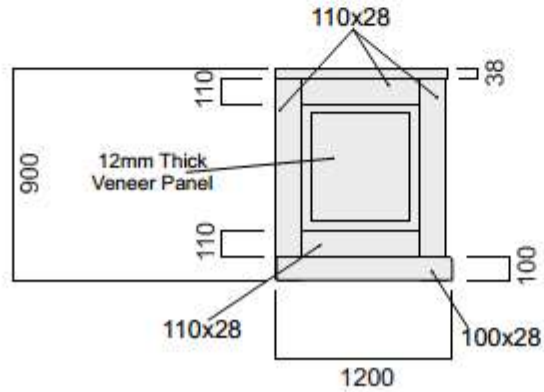

SIDE VIEW

CHAIR

Size : 500x490x1000

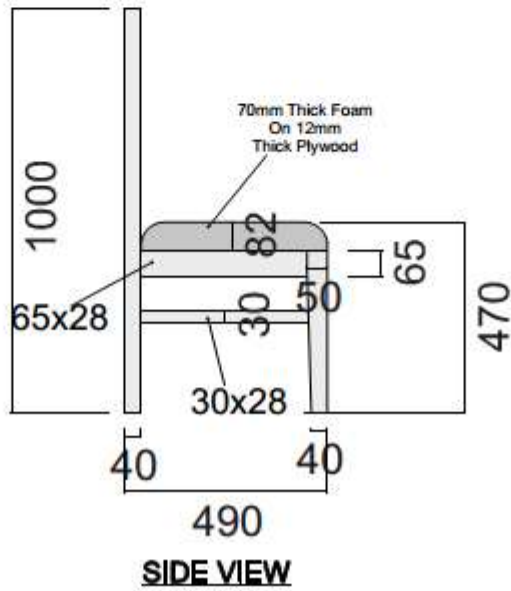
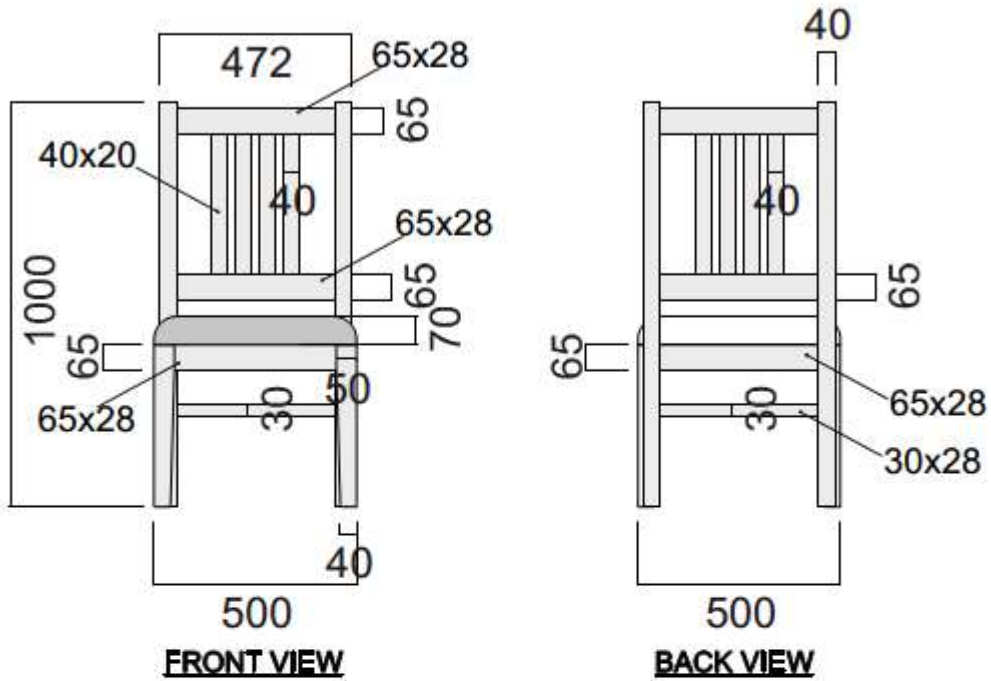

Witness Box
Size : 820x750x1180

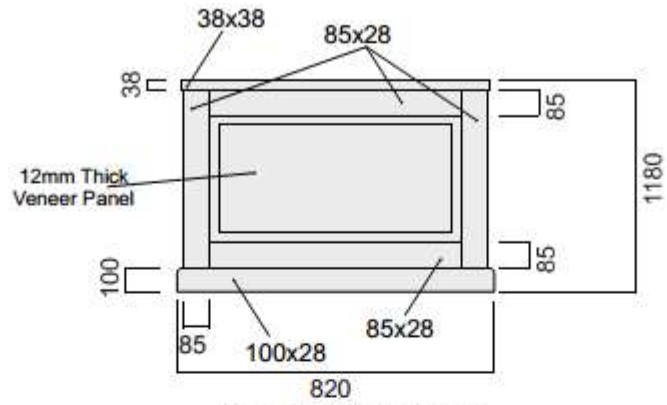

FRONT VIEW

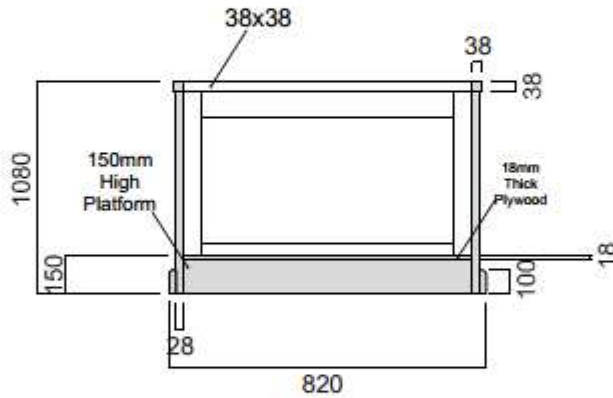

BACK VIEW

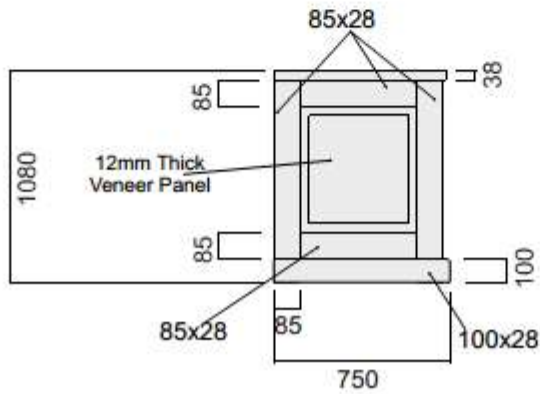

SIDE VIEW

Podium
Size : 600x450x1200

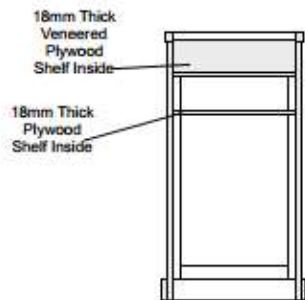
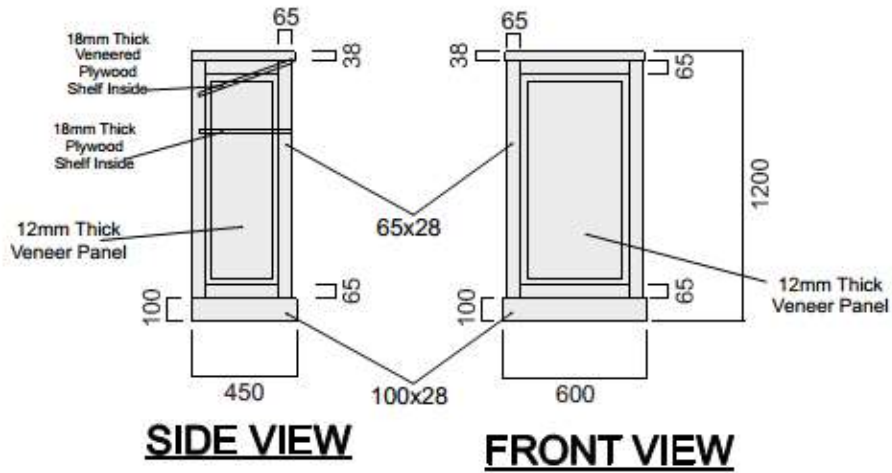

BACK VIEW

Sofa
Sofa 03 Seater - Size : 1900x700x880 (mm)
Sofa 01 Seater - Size : 850x700x880 (mm)

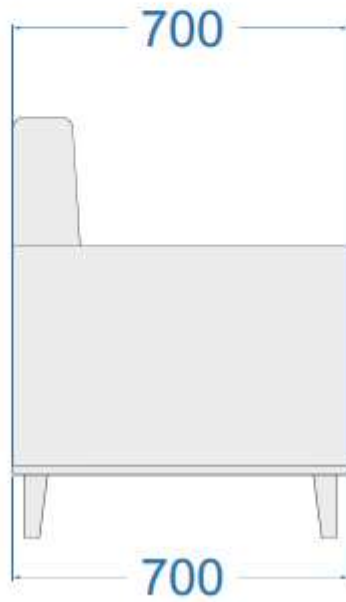
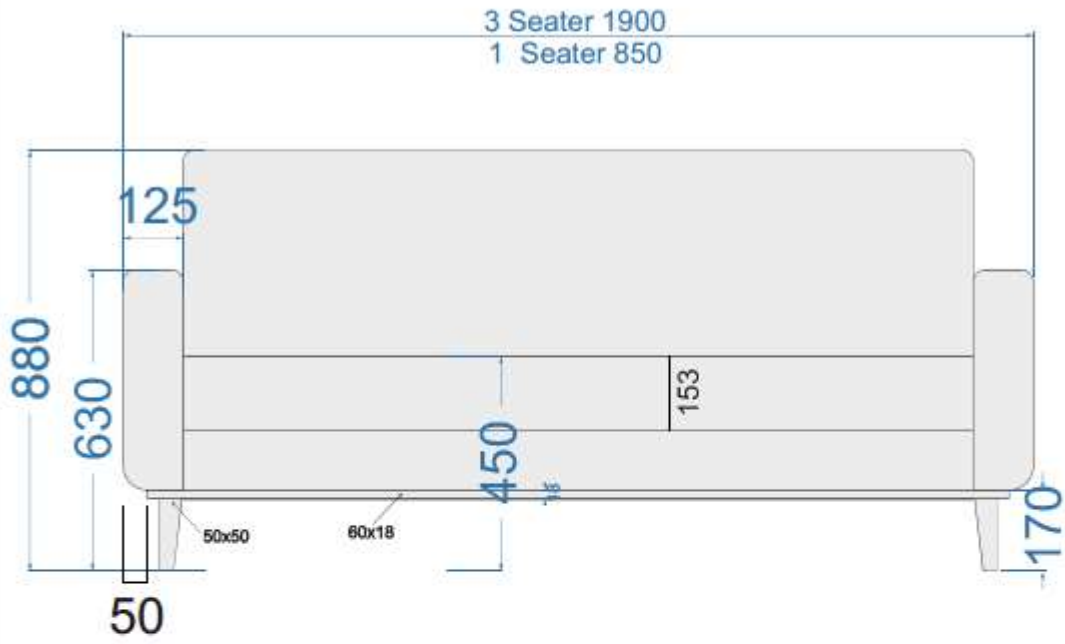

Center Table
Size : 1200 x 600x 450 (mm)

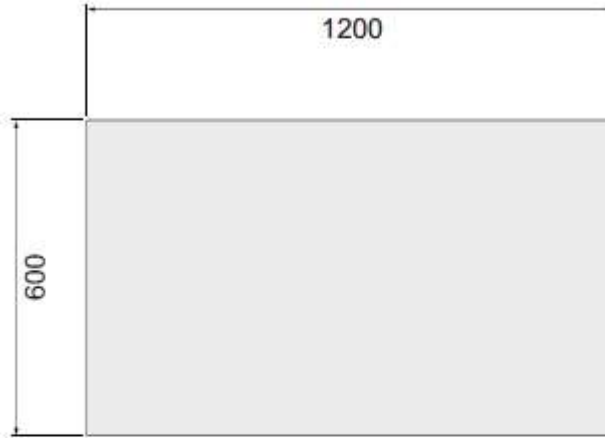

TOP VIEW

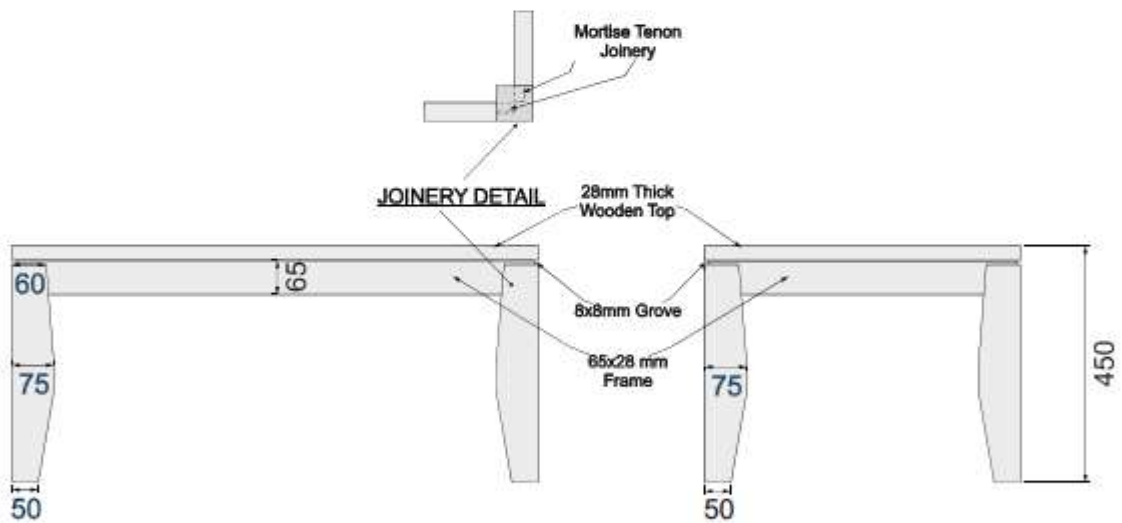

FRONT VIEW

SIDE VIEW

Painting

i) Painting priming coat of wood surface Primer for wood work shall be as specified in the description of the item otherwise shall be as per relevant IS Code and CPWD's specification . Surface to be primed shall be dry and thoroughly cleaned. All unevenness shall be rubbed down smooth with sand paper and shall be well dusted, knots, if any, shall be covered with preparation of red lead made by grinding red lead in water and mixing with strong glue sized and used hot. Appropriate wood filler material with same shade as paint shall be used where so specified.

The surface treated for knotting shall be dry before primer is applied. After the primer is applied the holes and indentation on the surface shall be stopped with glaziers putty or wood putty, stopping shall not be done before the priming coat.

ii) Painting priming coat on Iron & Steel surfaces

All rust and scales shall be removed by scrapping or by brushing with steel wire brushes. Hard skin of oxide formed on the surface of wrought iron during raking which becomes loose by rushing, shall be removed. All dust and dirt shall be thoroughly wiped away from the surface.

iii)The surface to be painted shall have received the approval of the Engineer In-charge after inspection, before painting is commenced. Application The number of coats including the under coat shall be stipulated in the item.

a)Under Coat

One coat of specified paint of shade suited to the shade of the top coat shall be applied and allowed to dry overnight. It shall be rubbed next day with the finest grade of wet abrasive paper to ensure a smooth and even surface, free from brush marks and all loose particles dusted off.

b)Top Coat

Tops coats of specified paint of desired shade shall be applied. Each coat shall be allowed to dry for not less than 24 hours and lightly rubbed down smooth with finest wet abrasion paper to get an even glossy surface. If, however, the surface is not satisfactory additional coats as required.

Painting on New Surface

SYNTHETIC ENAMEL PAINT

Synthetic Enamel Paint (conforming to IS: 1932 –1964) of approved brand and manufacture and of the required colour shall be used for the top coat and an undercoat of shade to match the top coat as recommended by the manufacturer shall be used.

Preparation of surface

a) Wood work

The surface shall be cleaned and all unevenness removed. Knots if available, shall be covered with a preparation of red lead. Holes and indentations on the surface shall be filled in with glazire's putty or wood putty and rubbed smooth before painting is done. The surface should be thoroughly dry before painting.

b) Iron and steel work

The priming coat shall have dried up completely before painting is started. Rust and scaling shall be carefully removed by scraping or by brushing with steel wire brushes. All dust and dirt shall be carefully and thoroughly wiped away.

POLISHING NEW SURFACE

Preparation of surface

a)The surface shall be cleaned. All unevenness shall be rubbed down smooth with sand paper and well dusted. Knots if visible shall be covered with a preparation of red lead and glue size laid on while hot. Holes and indentations on the surface shall be stopped with glazier's putty. The surface shall then be given a coat of wood filler made by mixing whiting (ground chalk) in methylated spirit at the rate of 1.5kg of whiting per litre of spirit. The surface shall again be rubbed down perfectly smooth with glass paper and wiped clean.

Application

The number of coats of polish to be applied to achieve the desired shade / finish. A pad of woollen cloth covered by a fine cloth shall be used to apply the polish. The pad shall be moistened with the polish and rubbed hard on the wood, in a series of overlapping circles applying the mixture sparingly but uniformly

over the entire area to give an even level surface. A trace of linseed oil on the face of the pad facilitates this operation. The surface shall be allowed to dry and the remaining coats applied in the same way. To finish off, the pad shall be covered with a fresh piece of clean fine cotton cloth slightly dampened with methylated spirit and rubbed lightly and quickly with circular motions. The finished surface shall have a uniform texture and high gloss.

MELAMINE POLISH/FINISH

Timber works shall be finished by the application of two coats and catalysed clear lacquer (melamine) wherever it is indicated in the drawing/specified. The finish shall be a stain semi-gloss finish and shall be carried out as follows:

The base shall be sand papered to the desired finish and coated with a colour tints to give it shade. This shade shall be sealed with a coat of spirit finish. After the base, first coat of melamine shall be applied evenly by spray to give an even coat to the veneer/wood surface.

After the first coat has fully dried, the surface shall be rubbed down in the direction of the veneer/ wood grain with very fine glass paper and left completely smooth and clean before the second coat is applied.

When the second coat of melamine is fully dry, the surface shall be rubbed down in the direction of veneer grain with very fine wire dipped in a petroleum based wax to give lubrication. Twenty four hours after completion of this process the melamine veneer/wood surface shall be finished by burnishing a soft cloth to an approved texture.

TECHNICAL BID PROFORMA

NIT No. :		CUSB/PSD/LAW/TENDER/03/2020-21 Dated:01/09/2020			
Tender for the Supply & Installation of Furniture for “Establishing the Moot Court and Legal Aid Clinic” at Central University of South Bihar, Gaya					
1.	Name of the Organization				
2.	Head Office / Registered Office				
	Telephone No/mobile No.				
	Fax No.				
	Email				
	Web site (if any)				
	Date of Establishment				
	Branch Office in Gaya , if any				
	(Provide Complete Address)				
	Telephone No.				
	Fax No./Email				
3.	Name of Chief Executive/ Proprietor / Partners with Designation				
	Telephone No./Mobile No.				
	Fax No./ Email				
4.	Name of Contact Person				
	Telephone No./Mobile No				
	Fax No./Email				
5.	Type of Organization		Certified Documents to be enclosed		
a.	Proprietary		Trade License		
b.	Partnership		Partnership Deed, Trade License		
c.	Private Limited Company		Memorandum of Article		
d.	Public Limited Company		Certificate of Registration		
e.	Public Sector		Trade License		
6.	Nature of Business (tick the relevant)				
Manufacturing		Service		Dealership	
Stockiest		Indian Agent		Indian Branch Office	
Others Pl. Specify					

7.	Class / Type of Product / Materials Manufactured / Sold / Serviced/ Fabricated				
Scientific Equipment		Electronics		Lab Consumables & Chemicals	
Electrical Items		Computer Peripherals		Computers	
Laboratory Equipments		Office Automation Product		Electrical Works	
Sport Materials		Water Coolers		Air-conditioners	
AV Equipments		Boards		Other, please specify.....	
Audited Annual Turnover during last 3 years (Rs. In Lakhs) (enclose Chartered Accountant's certification & Income Tax Return Copy)					
Year		Rupees (in Lakhs)		Annexure (Number)	
2017-18					
2016-17					
2015-16					
MSME Entrepreneur				Comments	
Is the bidder MSME Entrepreneur					
If yes, the category (GEN/OBC/SC/ST/Women)					

8. Commercial Information (enclose Attested Copy wherever Applicable)				
S. No.	Information	Details		Annexure (Number)
a.	GST Registration Number			
b.	Excise Registration Number Trade / Factory License Number			
c.	PAN No.			
d.	Details of Registration Certificate with DGS&D/NCCF			
e.	MSME/SSI/NSIC Certificate			
f.	Current dealership agreement with Principal Letter No. / Date / Valid upto			
g.	Relevant IISI/ SO Certificate, if any			
h.	<u>Bank Details :</u> Account No.			
i.	Name of Bank & Branch			
j.	IFSC Code			
k.	Details of Tender Fee	Amount:	DD Details:	Name of the issuing Bank & Branch
l.	Details of EMD	Amount:	DD Details:	Name of the issuing Bank & Branch
m.	Details of Previous Supply in Govt. Organisations/ Govt. Educational Institutions (Enclose Supply order & Performance report. If required enclose separate sheets)	Name of the organization	Item Supplied / Qty.	Total Value (Rs in lakhs)
I/ We hereby give an undertaking that the information provided are true to the best of my knowledge and belief. If anything found to be false at any stage my tender will be liable to be rejected and EMD amount will be forfeited.				
Signature of authorized representative:				
Date:				



Central University of South Bihar

(A Central University established under Central Universities Act 2009)

Bill of Quantities

for

Supply & Installation of Furniture for "Establishing the Moot Court and Legal Aid Clinic"

Financial Bid

Note : This is to be kept in **Envelope 'C'** sealed and it should be written on envelop that **Supply & Installation of "Moot Court and Legal Aid Clinic"** at Central University of South Bihar Gaya.



Central University of South Bihar

(A Central University established under Central Universities Act 2009)

(Price Bid)

(It should be kept in separate sealed envelope super scribed Price BID)

Bill of Quantity

Name of Work: Supply & Installation of Furniture for "Establishing the Moot Court and Legal Aid Clinic" at permanent campus of Central University of South Bihar, Panchanpur, Gaya (Bihar)

NIT No.: CUSB/PSD/LAW/Tender/03/2020-21,

Dated: 01/09/2020

Sl. No.	Item Description	Qty. (Nos.)	Rate/Unit	Total Amount (Inclusive of GST Charges)
1.	Wooden Platform with side Steps	1		
2.	Wooden Judge Table	1		
3.	Wooden Court Master Table	2		
4.	Wooden Executive Table	1		
5.	Wooden Chair	3		
6.	Wooden Witness Box	2		
7.	Wooden Podium	8		
8.	Sofa 3 Seater	2		
9.	Sofa 1 Seater	4		
10.	Wooden Centre Table	2		
11.	Indian Emblem (Wooden)	1		
12.	Wooden Hammer (with Base)	1		
Amount Total F.O.R. CUSB Gaya (INR)				

Total Amount in Figure inclusive of all Taxes/GST/Others

Total percentage of GST already considered in above rate =.....%

Total Amount inclusive of all taxes in Words

Date :

Seal & Sign of Vendor

Note : No Overwriting or use of Fluid/ Eraz-x is permitted. If done is liable to be rejected.

CERTIFICATE
(to be provided on letter head of the firm)

I hereby certify that the above firm has not been ever blacklisted by any Central/State Government/Public Undertaking/Institute on any account.

I also certify that the above information is true and correct in all respect and in any case at a later date, if it is found that any details provided above are incorrect, then the contract given to the above firm may be summarily terminated and the firm may be blacklisted.

Date:
Place:

Authorized Signatory
Name:
Seal
Designation:
Contact No.:

AFFIDAVIT

(on ₹ 100/- Non Judicial Stamp Paper duly attested by Magistrate/ Notary)

1. I/We the undersigned do hereby certify that all the statements made in the required attachments are true and correct.

2. The undersigned also hereby certifies that neither our firm M/s _____ have abandoned any work/supply nor any contract awarded to us for such works/supplies have been rescinded, during last three years prior to the date of this bid.

3. The undersigned hereby authorize and request any bank, person, firm or Corporation to furnish pertinent information deemed necessary as requested by the Central University of South Bihar, to verify this statement or regarding my (our) competence and general reputation.

4. The undersigned understands and agrees that further qualifying information may be requested, and agrees to furnish any such information at the request of the Central University of South Bihar.

(Signed by an Authorized Officer of the Firm)

Title of Officer

Name of Firm

Date:



CENTRAL UNIVERSITY OF SOUTH BIHAR

SH-7, Gaya- Panchanpur Road, Village- Karhara,
Post- Fatehpur, P.S- Tekari,
District- Gaya (Bihar) PIN- 824 236

UNDERTAKING

[by Tenderer(s)]

Name of the work : _____

Tender No. : _____

We confirm that we have quoted the rates in the tender considering Inter-alia the

1. Tender Document(s) with all Annexures, Scope of Vendor
2. Additional Document(s), if any
3. BOQ Document (Price Bid Format)
4. Corrigendum, if any
5. Pre Bid Meeting Minutes, if any

Signed for and on behalf of
Tenderer(s)

Name of Tenderer(s)

Date : __/__/____

Place :

Seal & Signature of Tenderer

Note :

This declaration should be signed by the Tenderer's authorized representative on COMPANY LETTERHEAD who is signing the Bid and to be submitted with tender.